

# ASSEMBLY INSTRUCTIONS & PARTS MANUAL

## Bulk Storage Shelving with Plywood Style Beams



RETAIN INSTRUCTIONS FOR FUTURE REFERENCE

LOAD CAPACITIES PER SHELF LEVEL *	
UNIT SIZE	WT. CAPACITY
48w x 24d	4150 lbs.
48w x 36d	3000 lbs.
48w x 48d	1500 lbs.
72w x 24d	2750 lbs.
72w x 36d	2750 lbs.
72w x 48d	2750 lbs.
96w x 24d	2150 lbs.
96w x 36d	2150 lbs.
96w x 48d	2150 lbs.

\* Load capacities based on evenly distributed loads



### GENERAL SAFETY INFORMATION

Some parts may have sharp edges. CARE must be taken when handling various pieces to avoid injury. For safety, wear a pair of work gloves when assembling or performing any maintenance on carts.

### LIMITED WARRANTY

Tennsco warrants goods purchased hereunder to be free of defects in materials and workmanship for a period of one (1) year from the date of shipment, hereunder. This warranty shall not apply in the event goods are damaged as a result of misuse, abuse, neglect, accident, improper application, modification or repair by persons not authorized by Seller, where goods are damaged during shipment, or where the date stamps on the goods have been defaced, modified or removed. UNLESS CONSIDERED UNENFORCEABLE OR UNLAWFUL UNDER APPLICABLE LAW:

- ALL IMPLIED WARRANTIES, INCLUDING BUT NOT LIMITED TO WARRANTIES OF MERCHANTABILITY AND FITNESS FOR A PARTICULAR PURPOSE ARE HEREBY EXCLUDED;
- BUYERS REMEDY, IF ANY, FOR ANY DEFECTIVE GOODS SHALL BE LIMITED TO A REFUND BY SELLER OR REPLACEMENT OF THE GOODS AT SELLER'S OPTION, AND SHALL IN NO EVENT INCLUDE DAMAGES OF ANY KIND, WHETHER INCIDENTAL, CONSEQUENTIAL OR OTHERWISE.

NO GOODS ACCEPTED FOR RETURN WITHOUT PRIOR APPROVAL. Seller shall have the right to inspect any goods claimed to be defective at Buyers place of business or require Buyer to return the goods to Seller for inspection on Seller's premises. Transportation charges covering returned goods will be borne by Seller only if such goods are proven to be defective, are covered by this warranty and are returned within the warranty period stated above.



**PROUDLY MADE IN THE U.S.A.**

Tennsco LLC., Dickson, TN 37056-1888 • (866) 446-8686

# ASSEMBLY OF BULK STORAGE SHELVING

**Tools Needed:** A rubber mallet for seating the shelf supports into the uprights.

Two people are recommended for assembly. Approximate assembly time: 20-30 minutes per section.

1. The reference numbers used throughout this sheet refer to the illustration on the back cover. This is to help you to identify the various parts as they are mentioned.
2. Lean one upright (Ref. No. 1) against the wall, or have an associate hold it for you.

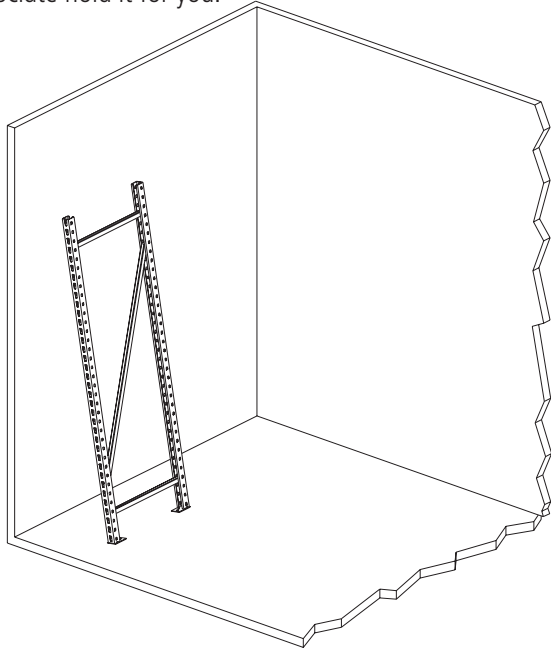

3. Attach one bottom beam (Ref. No. 2) to the upright, hooking the tapered fingers into the holes on the upright as shown in the drawings below.

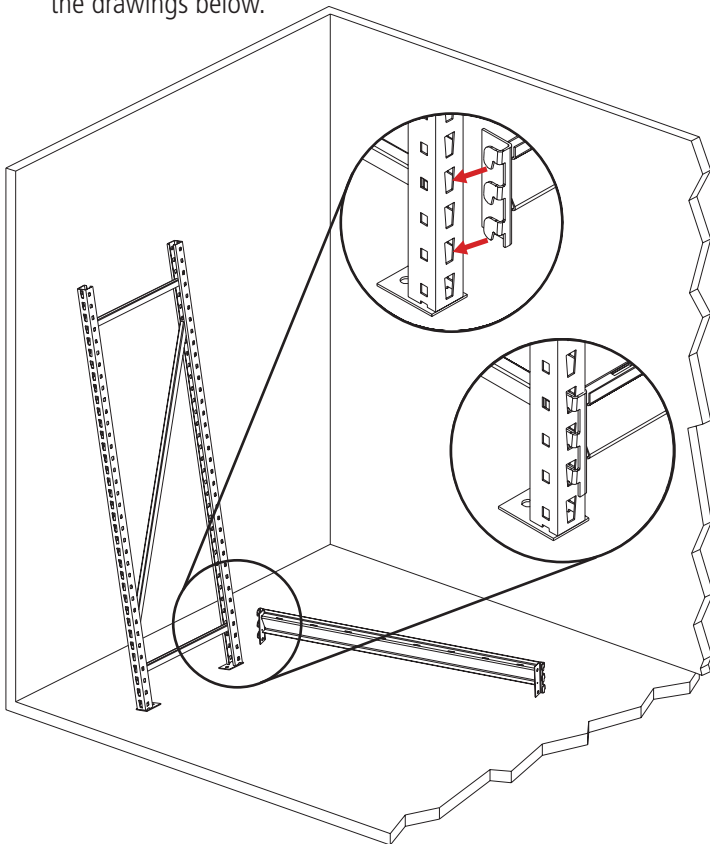

4. Attach the second bottom beam in the same manner as you did in step 3.

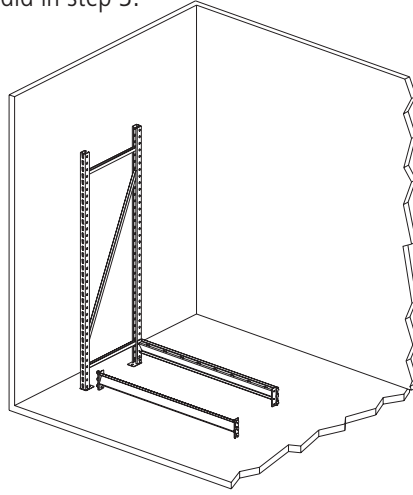

5. Holding the second upright in place, lift the loose ends of the two bottom beams and fit them into place on the upright. The unit should now have enough stability to stand up unassisted for the remainder of the assembly.

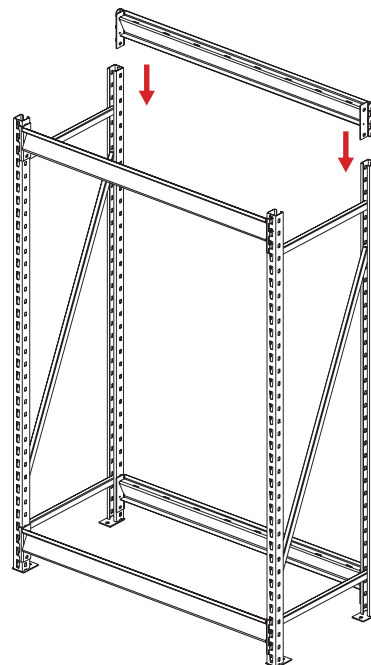
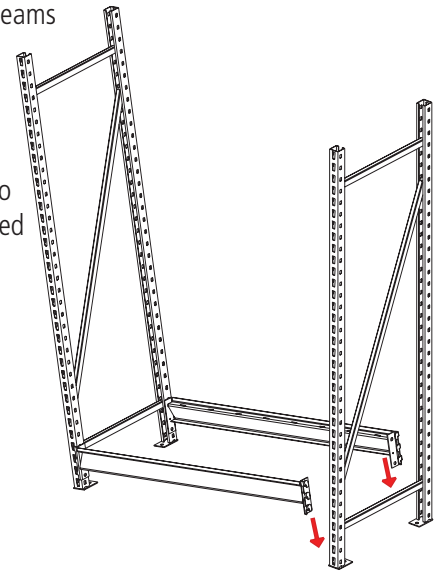

6. Attach the two top beams to the uprights at the desired level, using the same basic principals you used in steps 3 through 5.

7. Repeat step 6 to attach any additional shelf levels.

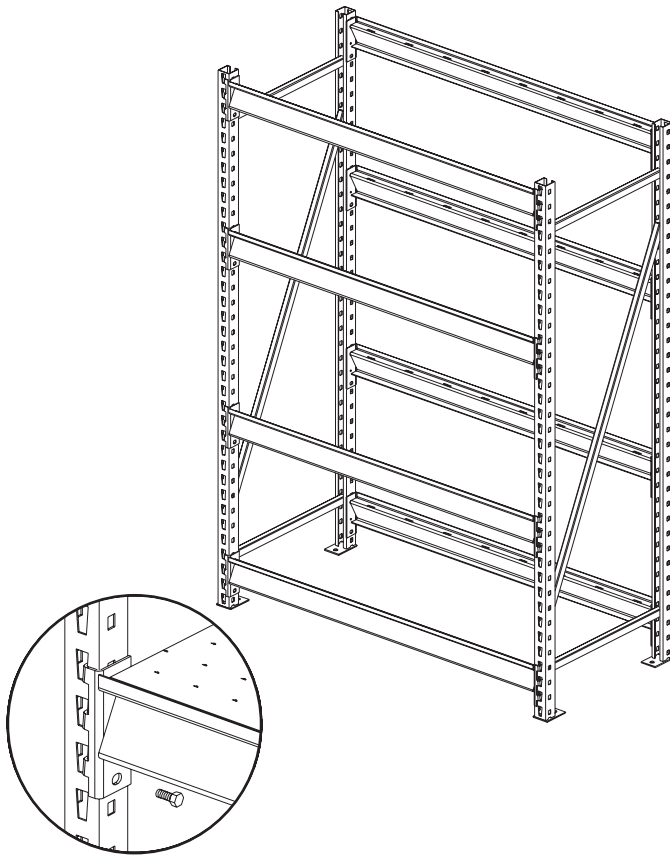

**NOTE:** As added prevention from beams dislodging, you can optionally place a bolt and nut (available locally) through each beam as shown.

8. Place the support angles (Ref. No. 3) on each shelf level by inserting the flanges into the slots on the beams. Be sure to space the support angles evenly to achieve maximum shelf strength.

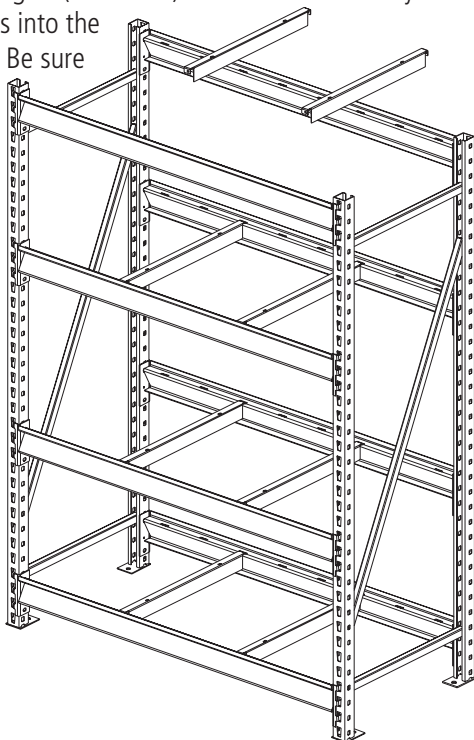

**NOTE:** Illustration shows two support angles per level. The number of support angles per level will vary depending upon the width and desired load capacity of your unit.

9. Place the shelf decking onto the shelf supports. The decking should fit into the supports so that the decking is flush with the edge of the shelf support.

**NOTE:** Particleboard decking is shown. Wire and Particleboard will be assembled the same. Corrugated instruction is listed below.

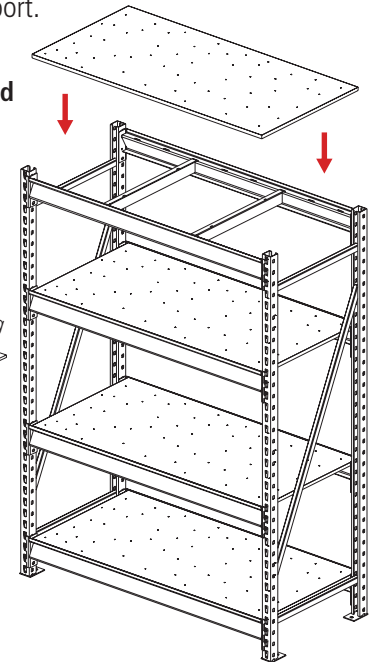
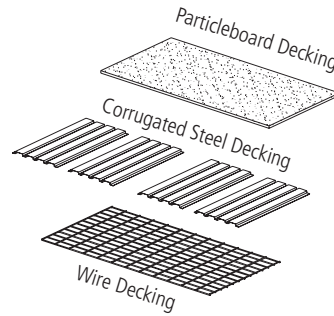

**NOTE:** To install corrugated steel decking: Steel decking comes in 12" sections that lay side by side on top of the rack beams. Please note the decking is not symmetric; one end flange is longer than the other (Figure 1). Normally, you would want to position the decking so the longer flange is below the shorter flange (Figure 2). However, if you want to take up some left to right slack, placing the longer flange on top spreads the decking out more (Figure 3).

FIGURE 1

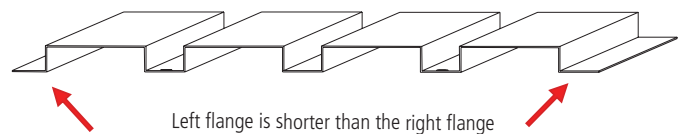
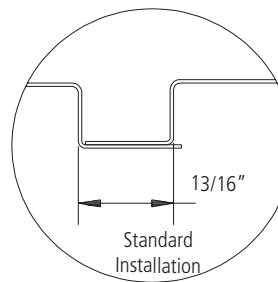
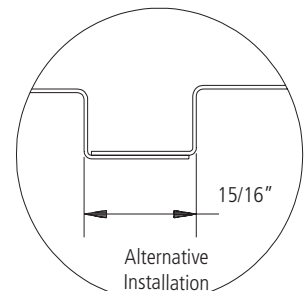

FIGURE 2



Standard Installation

FIGURE 3



Alternative Installation

10. Adder units share a common upright; simply insert the next row of beams onto the opposite side of the upright to extend your shelving.

11. Your shelving may be secured to the floor by bolting through the anchor holes located on each upright foot. Your bulk storage unit is now ready to use.

# REPLACEMENT PARTS

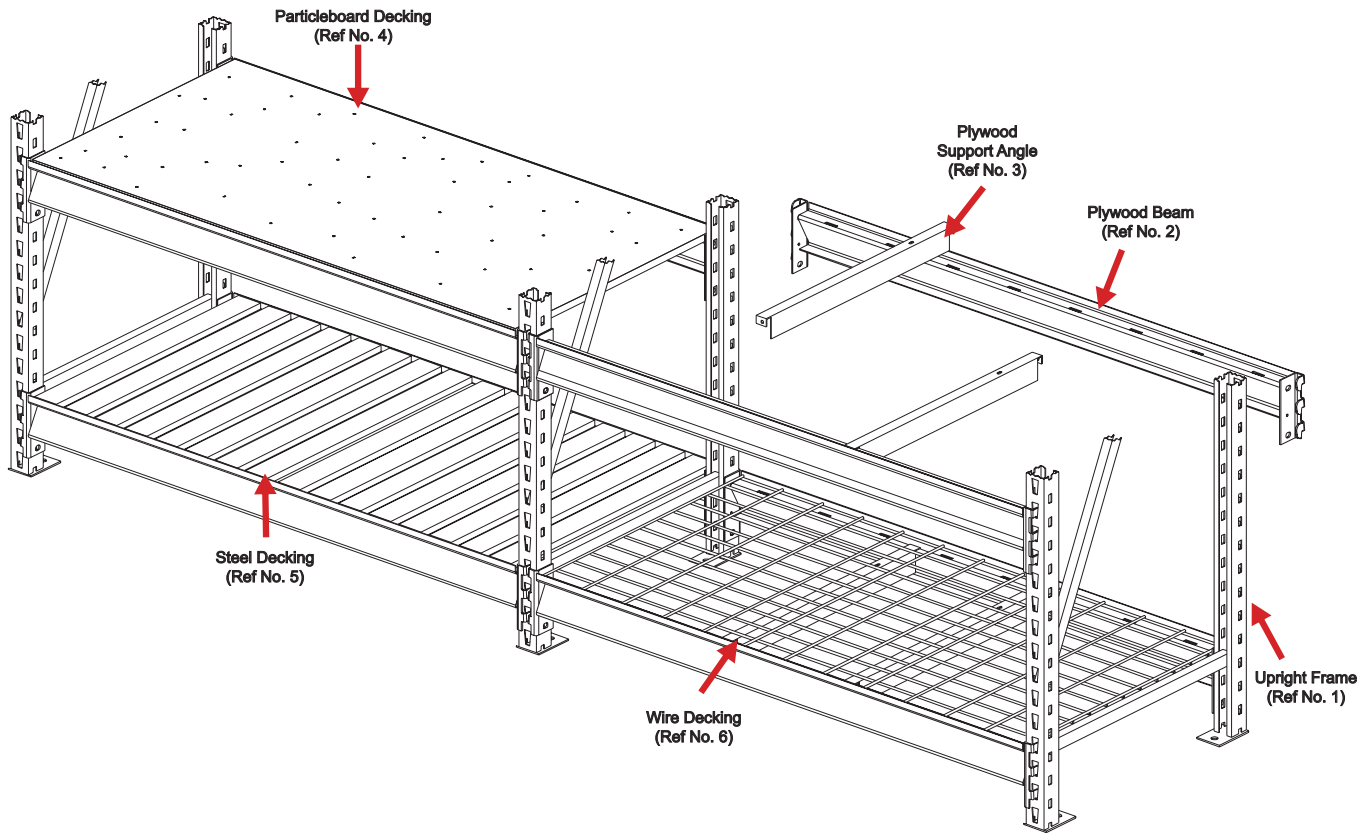

REF. NO.	DESCRIPTION	PART NO.
1	Upright Frame	BUF-ddhh
2	Plywood Beam	BPB-ww
3	Plywood Support Angle	BPS-dd
4	Optional Particle Board Decking	PB-wwdd
5	Optional Steel Decking	BSD-wwdd
6	Optional Wire Decking	ZWD-wwdd

Part No. is composed of prefix shown plus combination of opening of the unit. ww = Width, dd = Depth & hh = Height.

Bulk Units are to be hand loaded ONLY.

Tennsco makes every effort to ensure that all units ship complete with all parts and arrive undamaged. However, should your unit contain missing or damaged parts, please contact your purchase location.